



OPTIMUM 6

OPTIMUM 8

Optimum compactness

- Width of 76 cm to operate in the most congested areas
- Compact stowed height for easy access through standard doorways

Exceptional productivity

- Driveable at full height
- Load capacity up to 270 kg (Opt.6)
- Extended platform
- Long working cycles

Robust, reliable, easy to maintain



Haulotte 
GROUP
More than lifting



OPTIMUM 6 / OPTIMUM 8



ELECTRIC SCISSOR LIFTS

TECHNICAL DATA

	Optimum 6	Optimum 8
Working height	6.35 m	7.8 m
Platform height	4.35 m	5.8 m
Driveable at full height up to	4.35 m	5.8 m
Lift capacity - inside	270 kg	230 kg
Lift capacity - outside	270 kg	N/A
A Platform length - outside	1.68 m	1.68 m
B Platform length - extended	2.59 m	2.59 m
Length - extension	0.91 m	0.91 m
C Platform width - outside	0.7 m	0.7 m
D Storage height	1.91 m	2 m
E Height - stowed	1.91 m	2 m
F Overall width	0.76 m	0.76 m
G Length	1.9 m	1.9 m
H Wheelbase	1.38 m	1.38 m
I Ground clearance - Centre	8 cm	8 cm
Ground clearance - Pothole guards deployed	1.5 cm	1.5 cm
Drive speed	0.5 - 4.5 km/h	0.5 - 4.5 km/h
Gradeability	25 %	25 %
Tilt	2 °	2 °
Lift / lower speed	20 s / 35 s	22 s / 37 s
Turning radius - outside	1.7 m	1.7 m
Tyres - non marking	12.5 x 4.25	12.5 x 4.25
Batteries	24 V - 180 Amph (C5)	24 V - 180 Amph (C5)
Hydraulic system capacity	20 l	20 l
Weight	1290 kg	1370 kg

Optimum 8

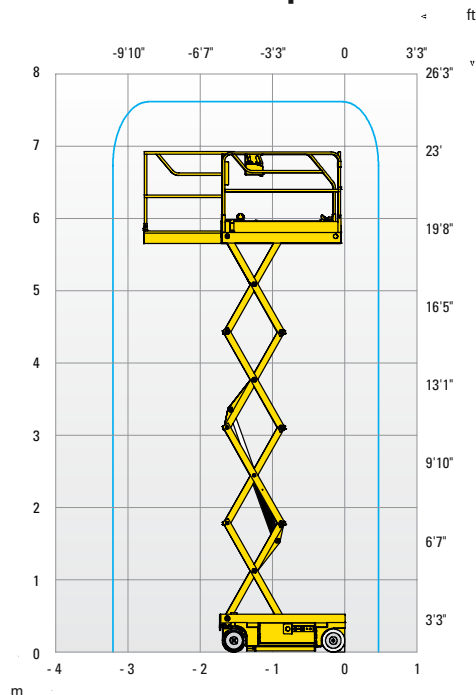

STANDARD EQUIPMENT

- Pothole guards
- Battery charge indicator
- Proportional lift and drive
- Inside / outside use (Optimum 6)
- Swing out component tray
- Battery charger with automatic stop
- Solid non-marking tyres
- Free wheeling device
- Tilt controller
- Load Management System in the platform
- Manual platform lowering valve
- Integrated forklift pockets
- Towing hooks
- Horn
- Hourmeter

OPTIONS AND ACCESSORIES

- Flashing light
- Travel alarm
- Working light
- Power to platform
- Biodegradable hydraulic oil
- Folding guardrails

